

Idea 40



10 preservation programs



Sequential vacuum



Smart sensor

Adaptable and complete

A line of chamber packing machines made entirely of stainless steel, including the complete outer body and vacuum chamber. They are characterized by a fully automatic packaging cycle and a digital control panel equipped with a microprocessor and 10 independent programs.

Idea 40 is ideal for:



Restaurants



Pastry shop



Butchers' shops



Pastry shops



Cafés

Packing methods



Sealing only



Vacuum



External vacuum

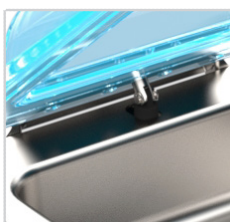

Accessibility
Opening system with support rod

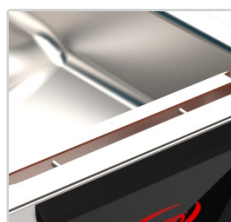

Easy vacuum
It is possible to vacuum pack outside the vacuum chamber

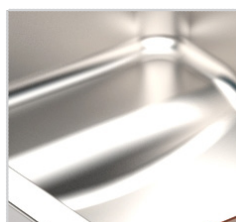

Hard-wearing vacuum chamber
Made in a single piece without weldings and rounded corners

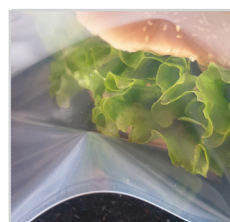

Gas vacuum
It vacuum packs even the most delicate and soft products



Digital panel
5" waterproof and scratch-resistant digital control panel

Technical data sheets

- > Bodywork: stainless steel
- > Size: 539x598x460h mm
- > Chamber size: 441x449x170h mm
- > Weight: 54,5 kg
- > Power grid voltage: 230V 50/60Hz
- > Max power absorption: 700 W
- > Sealing bars: 410 mm
- > Vacuum pump: 16 mc/h - 20mc/h
- > Max bag size: 400 mm

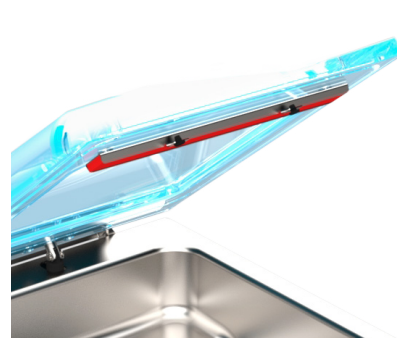
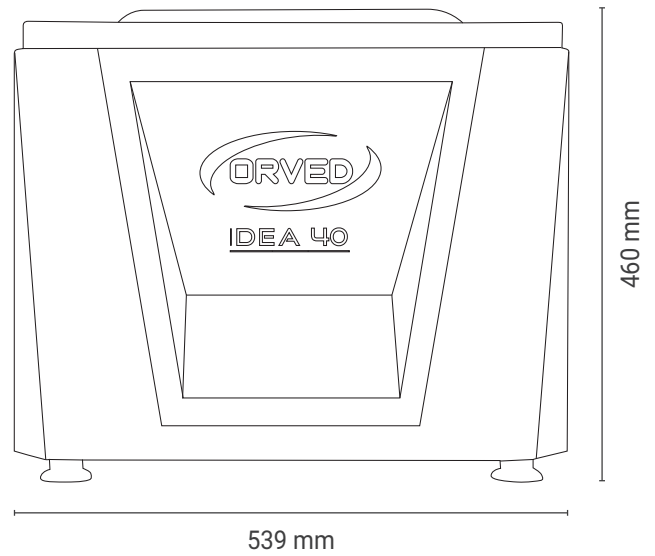

Standard equipment



Digital panel



Vacuum sensor



Customisable programmes



H₂out



Easy included



Vacuum in rigid containers

Matching accessories



Smooth vacuum bags



Channelled vacuum bags



Cooking vacuum bags



Carriage



Conserbox containers



Easy for external vacuum



Inclined shelf for liquid products